

GENERAL CERTIFICATION RULES METALLIC PRODUCTS	ARG	MPM
	VERSION 0.2	2026

# GENERAL RULES FOR THE CERTIFICATION IN THE FIELD OF METALLIC PRODUCTS

The valid version is available on the PROCERTUS [extranet](#).

# CONTENT

<b>1</b>	<b>GENERAL</b>	<b>3</b>
1.1	Object.....	3
1.2	Scope of certification .....	3
1.2.1	The BENOR mark and certification system .....	3
1.2.2	Certification for the CE marking .....	3
1.2.3	Certification for the PROCERTUS mark .....	4
1.3	Public documentation.....	4
1.4	Authorisation to use a mark .....	4
1.5	Conformity with ISO standards for conformity assessment as a principle .....	5
1.6	Concrete delegation of evaluation tasks.....	5
1.7	Cooperation and reciprocity .....	5
1.8	Use of languages.....	6
<b>2</b>	<b>ACCESS TO CERTIFICATION</b>	<b>6</b>
2.1	General conditions of access .....	6
2.2	Special access conditions for BENOR-CE-PROCERTUS certification .....	7
2.3	Application for certification .....	7
<b>3</b>	<b>ORGANISATION OF THE CERTIFICATION</b>	<b>8</b>
3.1	Modalities for the certification examination, the granting of certification and the right to use a mark .....	8
3.1.1	Processing of the application.....	8
3.1.2	Pre-audit.....	8
3.1.3	Initial Assessment.....	8
3.1.4	Surveillance.....	9
3.1.5	Use of Information Technology .....	10
3.1.6	Distress situations .....	10
3.2	Adjustments to the certification scope.....	10
3.3	Maintaining certification - Non-conformities - Sanctions.....	10
<b>4</b>	<b>FINANCIAL REGIME</b>	<b>12</b>
<b>5</b>	<b>APPEALS AGAINST CERTIFICATION DECISIONS</b>	<b>12</b>
<b>6</b>	<b>COMPLAINTS</b>	<b>12</b>
<b>7</b>	<b>USE OF MARKS AND LOGOS</b>	<b>12</b>
<b>8</b>	<b>HISTORY OF REVISIONS</b>	<b>12</b>
<b>APPENDIX A</b>		<b>13</b>
<b>APPENDIX B</b>		<b>14</b>

## **FOREWORD**

On 01.04.2024, the npo's PROBETON, BE-CERT, OCAB-OCBS and PROCERTUS merged in accordance with article 13 of the Code of Companies and Associations. On that date, PROBETON, BE-CERT and OCAB-OCBS were automatically dissolved, and all their rights and obligations were transferred to PROCERTUS, which alone continues their activities.

# **1 GENERAL**

## **1.1 Object**

This document contains the general principles, rules and modalities that apply to all certification schemes managed and applied by the npo PROCERTUS in the field of metallic products.

These principles, rules and modalities were previously defined and implemented by the npo OCAB-OCBS, which was responsible for these certification schemes until 31 March 2024.

On 1 April 2024, the activities of the npo OCAB-OCBS were taken over by the npo PROCERTUS and continued unchanged.

In the future, the principles, rules and modalities will be adapted to the changing preconditions and the general working methods of PROCERTUS.

## **1.2 Scope of certification**

These General Rules apply to the following certification systems:

### **1.2.1 The BENOR mark and certification system**

PROCERTUS, in succession to OCAB-OCBS, acts as a Sectoral Organisation, designated by the npo BENOR as a sub-licensee, and as certification body in the following areas:

- a) Reinforcing bars, rolled and drawn;
- b) Welded reinforcement meshes;
- c) Distributors of BENOR products;
- d) Lattice girders;
- e) Prestressing steel;
- f) Reinforcement centres-distributors;
- g) Flat panels;
- h) Mechanical connections.

### **1.2.2 Certification for the CE marking**

PROCERTUS acts as a notified body for the Construction Products Regulation EU 305/2011 under number 0965 in succession to OCAB-OCBS, which operated in that capacity under the number 1148 until 31 March 2024.

PROCERTUS has been notified for the metallic products sector for the following products:

- AVCP 1
  - Lighting columns according to EN 40-5, 6 and 7;
  - Fixed, vertical road traffic signs in accordance with EN 12899-1.
- AVCP 2
  - Steel and aluminium structures according to EN 1090-1;
  - Hot-rolled products of structural steel according to EN 10025-1;
  - Corrosion resisting steels according to EN 10088-4.

### 1.2.3 Certification for the PROCERTUS mark

In succession to OCAB-OCBS, PROCERTUS provides for specific certifications under its own mark, in consultation with the sector.

This system applies to:

- Distributors without production;
- Constructors with validation of additional data.

The application of a certification scheme to a specific type of product or domain is further referred to as a 'certification scheme' or abbreviated 'scheme'.

## 1.3 Public documentation

The publicly available documentation of PROCERTUS in the field of metallic products consists of three levels:

- **Level 1: the general level**, which includes the following documents:
  - these General Rules, referred to as ARG MPM;
  - TRA SPM: Safety Provisional Measures.
- **Level 2: the system level**
  - the documents introduced and imposed by the system owner;
  - the General Rules for each system, which are valid for all schemes (or part thereof) that fall under system, named ARG;
  - the Particular Rules per system, which are valid for all schemes (or part thereof) that fall under that system, named BRP.
- **Level 3: the scheme level**
  - the PTV (Prescriptions Techniques - Technische Voorschriften): the reference documents which allow prescribers to prescribe products under certification;
  - the TRA (Implementation Rules): the documents containing the certification rules applicable to specific products;
  - DTD: the requirements for the Technical Dossier of the certificate holder for specific products;
  - ECU: supporting documents relating to the control methods and equipment for certain products;
  - NRN: the Regulatory Notes supporting the evaluation methods described in Implementation documents.

Documents that are specifically applicable to each system and scheme are published on the PROCERTUS website, section metallic products.

Appendix A of this document gives a graphic representation of the document structure.

## 1.4 Authorisation to use a mark

If the granting of certification is accompanied by the authorisation of the use of a mark as proof of conformity, it will be considered as an inseparable whole and will be delivered and maintained simultaneously.

The scope of the certification will determine the authorised use of the mark.

This is the case for the BENOR and PROCERTUS certification systems, where PROCERTUS is either the manager or the owner of the mark.

PROCERTUS is not a mark manager for CE certification and its authority is limited to carrying out the assessment tasks and awarding the certification.

## 1.5 Conformity with ISO standards for conformity assessment as a principle

All activities of PROCERTUS in the field of metallic products are organised, as far as possible, in accordance with the requirements of the international standards ISO/IEC 17065 and ISO/IEC 17067.

If possible and relevant, the relevant schemes will be brought under accreditation by BELAC. This is the case for CE certification and for the majority of BENOR certification schemes.

Certificate holders may refer to the BELAC accreditation of PROCERTUS, provided that the provisions of section 4.1 of document BELAC 2-001 are respected.

If PROCERTUS entrusts evaluation tasks to other bodies in the context of certification activities for which it itself works under accreditation, it is required that the execution of these evaluation tasks complies with the corresponding standard of the ISO/IEC 17000 series:

- ISO/IEC 17020 for subcontracted inspections;
- ISO/IEC 12025 for testing in external control laboratories;
- ISO/IEC 17021-1 for the executions of audits of management systems (as part of the evaluation plan).

To the extent possible, PROCERTUS will request that the institutions concerned be accredited for these evaluation tasks.

In the absence of accreditation and for evaluation tasks that do not fall within the scope of these standards, PROCERTUS will itself be responsible for the qualification and quality monitoring of the implementers, using methods inspired by the relevant accreditation standards.

This is also the case for the execution of the evaluation tasks by its own staff, including service providers who have a direct contract with PROCERTUS in a personal capacity and are under its control (freelancers or one-man businesses).

## 1.6 Concrete delegation of evaluation tasks

In the field of metallic products, PROCERTUS works in permanent cooperation with recognised inspection bodies and laboratories. These are listed in tables that are published on the website.

Each of the recognised bodies has an agreement with PROCERTUS.

The inspection bodies are accredited per product or domain. For the inspection bodies, the assignments for the execution of the inspections and audits are given by PROCERTUS and a regular rotation of the inspectors/auditors is provided within a given domain, according to the available possibilities.

For external testing, the certificate holder can choose from the list of laboratories recognised by PROCERTUS. PROCERTUS reserves the right to designate the laboratory itself, depending on the risks of partiality or for special verifications.

Care is taken to ensure that no conflict of interest can arise when laboratories carry out both internal and external control tests for a particular certificate holder.

In special cases, individual cooperation agreements may be concluded in a given framework, which are not published as recognition.

## 1.7 Cooperation and reciprocity

In order to reduce the burden of external inspections and tests on the certificate holders, PROCERTUS provides for the possibility of concluding cooperation and reciprocity agreements with certification bodies in other countries.

This is the case, for example, with Dutch and German institutions, with EU notified bodies and UK-approved bodies.

In all cases, certification decisions are taken sovereignly on the basis of the equivalent execution of evaluation tasks according to its own rules and according to the principles of the ISO/IEC 17000 standards.

In the event that evaluations carried out in the context of another certification are used by PROCERTUS for the certification decisions, a verification of the suitability of this evaluation will be carried out by PROCERTUS. This can be done, among other things, by regularly attending the execution of these evaluations. The verification can be carried out by an approved inspection body under the surveillance of PROCERTUS.

The tables mentioned in 1.6 indicate in which areas and for which products current cooperation is possible.

## 1.8 Use of languages

The working languages for the basic operations are Dutch and French, both for the editing of public documents and for the handling of files.

Given the international nature of many of the activities, English will also be used as a third language. For specific activities, English may be used as the only language.

In special cases, German may be used in the context of handling files. The condition is that equivalence can be guaranteed and that the performers of the evaluation are proficient in the language. However, the reporting must be available in one of the three working languages. Costs caused by the use of the fourth language, for example for the translation of the report, will be charged additionally.

# 2 ACCESS TO CERTIFICATION

## 2.1 General conditions of access

PROCERTUS does not impose any preconditions for the possibility of applying for a certification other than those mentioned in the Particular Rules for each certification system.

In general, however, PROCERTUS requires that the applicant for certification undertakes to comply with all legal conditions for companies that are valid at the time of granting the certification in the countries where the applicant places the products on the market.

PROCERTUS will not check whether the conditions have been met, but may require the applicant to demonstrate this.

When granting the certification, PROCERTUS must dispose of a signed agreement in accordance with ISO/IEC 17065, confirming that the certified company accepts all specific conditions.

The agreements previously signed with OCAB-OCBS that were valid at the time of the transfer, will be continued by PROCERTUS.

The validity of the certification ends automatically in the event of bankruptcy or non-payment of the certified company. As soon as PROCERTUS learns about the bankruptcy, the certificate will be removed from the website.

The agreement contains at least the following obligations, most of which are already in force during the assessment for granting the initial certification, without the agreement having been concluded. This is already recorded in the signed application for certification.

- a) To comply at all times with the certification requirements documented in the applicable Rules, including the changes formally communicated by PROCERTUS.
- b) Guarantee that the certified products continuously meet the product requirements covered by the certification.
- c) Make all necessary arrangements to:
  - enable the assessment and follow-up, including the provision of all information for the examination, including documentation and registrations, access to the equipment, sites, areas and the personnel and subcontractors involved of the company to be certified or certified;
  - handle complaints;
  - when needed, allow for the participation of observers.
- d) Ensure consistency between the certification statements and the scope of the certification.

- e) Not to use the product certification in a way that could cause damage to PROCERTUS, nor to make any statements that could be considered unauthorised or fraudulent.
- f) In the event of suspension, withdrawal or discontinuation of the certification, cease all communication referring to the certification and comply with all the requirements provided for in the certification Rules, such as the return of certificates, if they have been delivered manually signed in paper form.
- g) In the event that certification documents granted are made available to the market, they must be reproduced unchanged and in full, or in the authorised form specified by the Rules.
- h) Comply with the requirements of the certification Rules and the instructions of PROCERTUS in information carriers, such as documents and brochures relating to certification notices.
- i) Comply with all PROCERTUS guidelines regarding the use of the marks that PROCERTUS authorises.
- j) To keep a register of all complaints of which the certified company is aware relating to conformity with the certification requirements, and to make this register available to PROCERTUS on request. Taking all necessary actions to handle the complaints and to avoid and eliminate the risks of non-conformity of the products, and documenting these actions.
- k) Inform PROCERTUS without delay of any changes that may affect the company's ability to meet certification requirements, such as:
  - ownership or legal, commercial or organisational status;
  - the organisation and management (key persons such as administrators, decision-makers or technical experts);
  - modifications to the product or production method;
  - the contact details of the persons involved and the production sites;
  - significant changes to the quality management system.

## 2.2 Special access conditions for BENOR-CE-PROCERTUS certification

The special conditions of access for certification are specified in the Particular Rules for each certification system (BENOR, CE or PROCERTUS).

## 2.3 Application for certification

The application for certification is made by submitting a duly completed and signed form, which is available on the PROCERTUS website (part metallic products).

By signing the form, the applicant accepts the general and special terms and conditions specific to the system and the scheme for the product or domain in question.

The applicable documents are available on the site.

The application must be submitted to PROCERTUS in writing or digitally. If the application was initially submitted informally to PROCERTUS, PROCERTUS will provide the applicant with an application form. The documents concerned can be consulted on the website.

Standards or normative documents that are not managed by PROCERTUS cannot be made available by PROCERTUS and must be obtained from the responsible publisher. In most cases, these are the standardisation bodies.

In the event that the application does not fall within the competence of PROCERTUS, PROCERTUS will inform the applicant accordingly.

An application can only be submitted by a person who has a valid authority on behalf of the company to be certified and who can commit the company to the obligations to be taken in the context of the certification.

PROCERTUS is not obliged to respond to requests with questionable deontology (e.g. resulting from industrial espionage, companies in poor financial condition or unfair commercial practices). In the event that the applicant demands a formal response, PROCERTUS will provide the justification for the refusal of treatment.

## 3 ORGANISATION OF THE CERTIFICATION

### 3.1 Modalities for the certification examination, the granting of certification and the right to use a mark

#### 3.1.1 Processing of the application

Upon receipt of an application, a file manager will organise the initial certification.

One of the conditions for obtaining certification, is the realisation of a truthful and compliant Technical Dossier, which is positively assessed. The final version of this Technical Dossier must be available at the time of the granting of the certification and must have been evaluated favourably.

The file manager will verify the admissibility of the application and whether PROCERTUS has the necessary resources and competence to process the application effectively and within a reasonable timeframe.

If these conditions are met, PROCERTUS will appoint a suitable evaluator. This is either an inspector/auditor specific to PROCERTUS or an inspection body. The appointment of the evaluator shall be notified to the applicant. Unless there are justified objections, this appointment cannot be contested.

This evaluator will conduct the initial examination in accordance with the evaluation plan as described in the applicable Implementation Rules, including the assessment of the Technical Dossier.

#### 3.1.2 Pre-audit

At the request of the applicant, a pre-audit may be carried out on an optional basis. In that case, a specific cost estimate will be made. The purpose of the pre-audit is to allow the applicant to evaluate his situation in relation to the regulatory requirements.

The evaluator's report shall be forwarded to the file manager and may also be used as a basis for the preparation of the initial assessment report.

#### 3.1.3 Initial Assessment

As part of the assessment assignment for an initial certification, the evaluator schedules the necessary site visits and tests in accordance with the Implementation Rules.

Once the visits have been completed and the results of the tests have been received from external laboratories, the evaluator draws up an assessment report with an advice about the awarding of the certification:

- In the event of a favourable advice, the assessment report is forwarded to the file manager, who reviews the report and approves it for submission to the Technical Advice Expert Group and the Certification Committee.
- The Technical Advice Expert Group issues an advice in full confidentiality, on the basis of which the Certification Committee takes the decision.
- In the event of a negative advice or doubt, the file manager will also be informed, and may request the advice of the Technical Advice Expert Group. This Expert Group shall give a collegial advice on the further steps to be taken in the assessment. All advices are considered by the Certification Committee.
- The Certification Committee takes a decision on the certifiability of the dossier at this stage and the steps to be taken for further assessment.
- The file manager informs the applicant about the decision and the further steps to be taken.
- If the certification cannot yet be granted, an additional assessment plan may be imposed and implemented until a favourable advice can be obtained.

In the event of a favourable decision, an agreement will be drawn up for the commencement and maintenance of the certification. This will be signed and delivered to the applicant by PROCERTUS.

The agreement contains all the rules and measures for maintaining certification and, where applicable, for the authorisation to use the mark.

This agreement is not reaffirmed for an extension or change in the scope of the certified products. The initial agreement

remains indeed applicable during the entire period of validity of the certification.

After signing the agreement, a certificate will be issued to the certificate holder. The certificate is valid from the date of receipt of the agreement. Special provisions in this regard are included in the Particular Rules (BRP).

The certificate is updated every time the scope of the certification changes.

The certificate is published on the PROCERTUS website and can be consulted there.

Specific provisions with regard to the initial examination and the issuance of the certificates are included in the BRP or TRA.

### 3.1.4 Surveillance

For maintaining the certification, surveillance is carried out. Surveillance consists of regular audits, inspections and laboratory tests in external control laboratories, including the review of the Technical Dossier and the autocontrol results.

The programme and the periodicity of the regular controls are laid down in the TRA for each scheme.

The inspections and audits are carried out by our own inspectors/auditors or by accredited inspection bodies.

The inspections are distributed annually among the available inspectors, with a regular rotation applied. At the end of each working year, the certificate holder is informed of the inspector/auditor or inspection body designated for his file.

The inspections can be carried out unannounced. The certificate holder cannot demand to be informed in advance.

After each visit, the inspector/auditor shall draw up an inspection/audit report with, where appropriate, non-conformity sheets.

Non-conformities detected outside the visits may also be subject to non-conformity sheets.

The inspection or audit report and the accompanying sheets shall be drawn up, as far as possible, on the spot at the end of the visit, including the non-conformity sheets. Acknowledgement for the report shall be confirmed on the spot by the certificate holder. If the report cannot be drawn up on the spot, it will be sent no later than 20 days after the visit, depending on the nature of the findings.

The processing of non-conformity sheets is, in principle, carried out in accordance with the scheme set out in the annex. The certificate holder shall take the necessary measures for each non-conformity sheet and shall provide the inspection body or inspector/auditor with the corresponding action plan. The inspector/auditor follows up on the actions and closes the non-conformity sheets as soon as possible. Sheets from previous visits that have not been closed will be updated and added to the next reports.

The full report, including the non-conformity sheets and the action plans of the certificate holder, is sent to PROCERTUS and checked by the file manager.

Depending on the findings, the necessary decisions are taken regarding the maintaining of the certification, additional controls and possible adjustments to the control regime.

If, in the context of reciprocity, inspections by other institutions are used, the body appointed by PROCERTUS will check and interpret the reports. The institution appointed by PROCERTUS will regularly attend a visit by the other institution.

During the inspection visits, the body appointed by PROCERTUS will carry out the planned sampling and have it delivered to an accredited laboratory.

After receiving the results, the inspection body or inspector/auditor will interpret them according to the provided procedure and report the findings to the certificate holder and PROCERTUS, with the necessary advice for a decision on whether to maintain the certification.

The Technical Dossier and autocontrol results, which are made available by the certificate holder by written or digital means, are assessed by the inspector.

The results of the assessment shall be communicated to PROCERTUS, either in the form of the inspection visit reports or in separate reports.

### 3.1.5 Use of Information Technology

In specific cases, periodic controls can be carried out through the use of information technology without an on-site visit. The report must clearly state this choice.

Taking into account the certification agreement, the staff of the certification body must have easy access to the staff and resources of the certificate holder in order to ensure that the assessments provided for in the agreement can be carried out, provided an appropriate but equivalent working method.

The certification body reserves the right to determine the choice of working method and, if necessary, to impose an on-site audit.

### 3.1.6 Distress situations

If, in exceptional circumstances, regardless of the will of the certificate holder, PROCERTUS or its subcontractors, the visits cannot be carried out on site, a special procedure applies: « Safety Provisional Measures » (cf. TRA-SPM).

## 3.2 Adjustments to the certification scope

For any adjustment of the scope of the certification as stated on the certificate, e.g. the types of products, the production units and the declared performances, an extension examination must be carried out according to the same modalities as for the initial certification examination.

The certificate holder is obliged to notify any change in the scope of the certification before he can make use of the certification of the changed element.

Any breach of the use of the certification outside the scope stated on the certificate may result in the suspension, withdrawal or restriction of the certificate.

After a favourable advice, PROCERTUS will issue an additional or amended certificate and the agreement will be amended or extended.

The specific procedures for modifications and extensions are explained in the applicable BRP and TRA.

## 3.3 Maintaining certification - Non-conformities - Sanctions

The certification can only be maintained if, on a permanent basis, the certificate holder continues to comply with the obligations and the object of the certification is in conformity with the Rules and, where applicable, the use of the mark is correct.

Depending on the findings made during the surveillance, PROCERTUS will take the necessary measures with regard to the maintaining of the certification, the carrying out of additional controls, the adjustment of the control regime or other sanctions.

The findings, whether made during the inspection visits or not, are classified as follows:

- Major non-conformity

A major non-conformity means that the products that are placed on the market under certification or the management system of the certificate holder do not meet the requirements for the certification.

Such non-conformity jeopardises the quality of the products and indicates the ineffectiveness of the production control.

- Minor non-conformity

A minor non-conformity stands for an occasional shortcoming for a specific activity. This type of non-conformity can jeopardise the quality of the products or the effectiveness of the certificate holder's management system in the long term. Minor non-conformities are often of an administrative nature.

A succession of minor non-conformities can reveal a deeper serious problem and give rise to a major non-conformity.

- **Remark**

A remark is the result of a punctual observation and is not a true non-conformity. It is notified to the certificate holder for information and is a point of attention for the next control.

The non-conformities are followed up by the evaluator. The follow-up is reported to PROCERTUS. Based on the information and advice of the evaluator, PROCERTUS can make decisions regarding the maintaining of the certification or adjustment of the control regime. PROCERTUS can also ask questions to the certificate holder with regard to identified problems.

The determination of the severity of the problems is specific to the experience built up per schedule and the risks caused by the problems.

The possible sanctions are as follows:

- **Summation:**

The summation is a sanction resulting from the discovery of a non-conformity, notified in writing by an inspection body, with notification to PROCERTUS, or by PROCERTUS in the case of an inspection by an inspector by PROCERTUS itself. The inspection body shall follow up on the corrective measures. If there is insufficient response, this may lead to a heavier sanction.

- **Warning:**

The warning is a written notification by PROCERTUS of the finding of a non-conformity which, in the event of insufficient corrective action, may lead to a more severe sanction.

- **Reinforced control**

This sanction consists of additional inspection visits or additional tests in external laboratories, which must be paid for separately by the certificate holder. They serve to get a clearer picture of the compliance problems and the corrective actions.

- **Penalty**

This is a fee that covers the additional treatment of the problems by PROCERTUS, usually linked to reinforced control.

- **Temporary suspension of autonomous delivery**

This sanction suspends the autonomous use of the mark. However, production control will be continued, as will the surveillance thereof. The use of the mark can only be exerted with the approval of PROCERTUS when the conformity of the products has been demonstrated. The suspension of autonomous delivery can only be maintained for one year and then turns into full suspension.

- **Suspension of certification**

In this case, the certification and, where appropriate, the use of the mark shall be suspended.

The certificate will be invalid and will generally be removed from the website. If judged relevant to the user, the certificate can remain present on the website indicating the suspension. The certification can only be reactivated if it has been established that there can be confidence in the operation of the production control and/or the conformity of the products.

Therefore, control is maintained in whole or in part during the suspension period.

A suspension may only last for two years and then automatically turns into a withdrawal.

- **Withdrawal**

In the event of withdrawal, the certificate holder shall lose the certificate and, where applicable, the authorisation to use the mark. He can only obtain it again after a new admission examination and demonstration that he can meet the conditions.

Individual principles for the sanctions are determined for each system or scheme.

## 4 FINANCIAL REGIME

The tariff regimes are determined by type of product or domain and are published on the PROCERTUS website.

The services charged for the same evaluation task are independent of the choice of the inspection body or the inspector/auditor.

The payment term is 30 calendar days. If this payment term is exceeded, PROCERTUS reserves the right to suspend the validity of the certification until the invoices have been settled.

PROCERTUS has the right to carry out the necessary controls in the event of a request from the certificate holder to lift a suspension and to charge the costs thereof to the certificate holder.

In order to avoid non-payment in case of doubt, PROCERTUS may decide to request advance payment from the certificate holder before the controls are carried out.

## 5 APPEALS AGAINST CERTIFICATION DECISIONS

A certificate holder can lodge an appeal against a certification decision. The procedures for dealing with hearings and appeals against certification decisions are set out in the general documentation of PROCERTUS.

## 6 COMPLAINTS

Any party that has a complaint regarding the operation of the certification or regarding non-conforming products under certification, may submit a complaint to PROCERTUS.

Every complaint must be substantiated by demonstrable data.

The procedures for submitting and handling complaints are set out in the general documentation of PROCERTUS.

## 7 USE OF MARKS AND LOGOS

The rules for the use of the marks owned or managed by PROCERTUS are described in the documentation for the relevant certification system.

In the event of non-compliance with these rules, PROCERTUS will take appropriate measures in the form of sanctions as described in 3.3.

Unlawful use of the mark by parties who are not holders of a certificate will be prosecuted.

## 8 HISTORY OF REVISIONS

**Revision 0, creation**

**Revision 0.1, various modifications including §3.1.3 (reaffirming the agreement) and §5 (referring in full to PROCERTUS procedure)**

**Revision 0.2, §1.5 (addition of an encouragement to use the BELAC logo) and §3.1.4 and APPENDIX B (relocation of the scheme for the processing of non-conformity sheets)**

# APPENDIX A

Fig. 1 Overview of the document structure of PROCERTUS Cluster Metallic Products

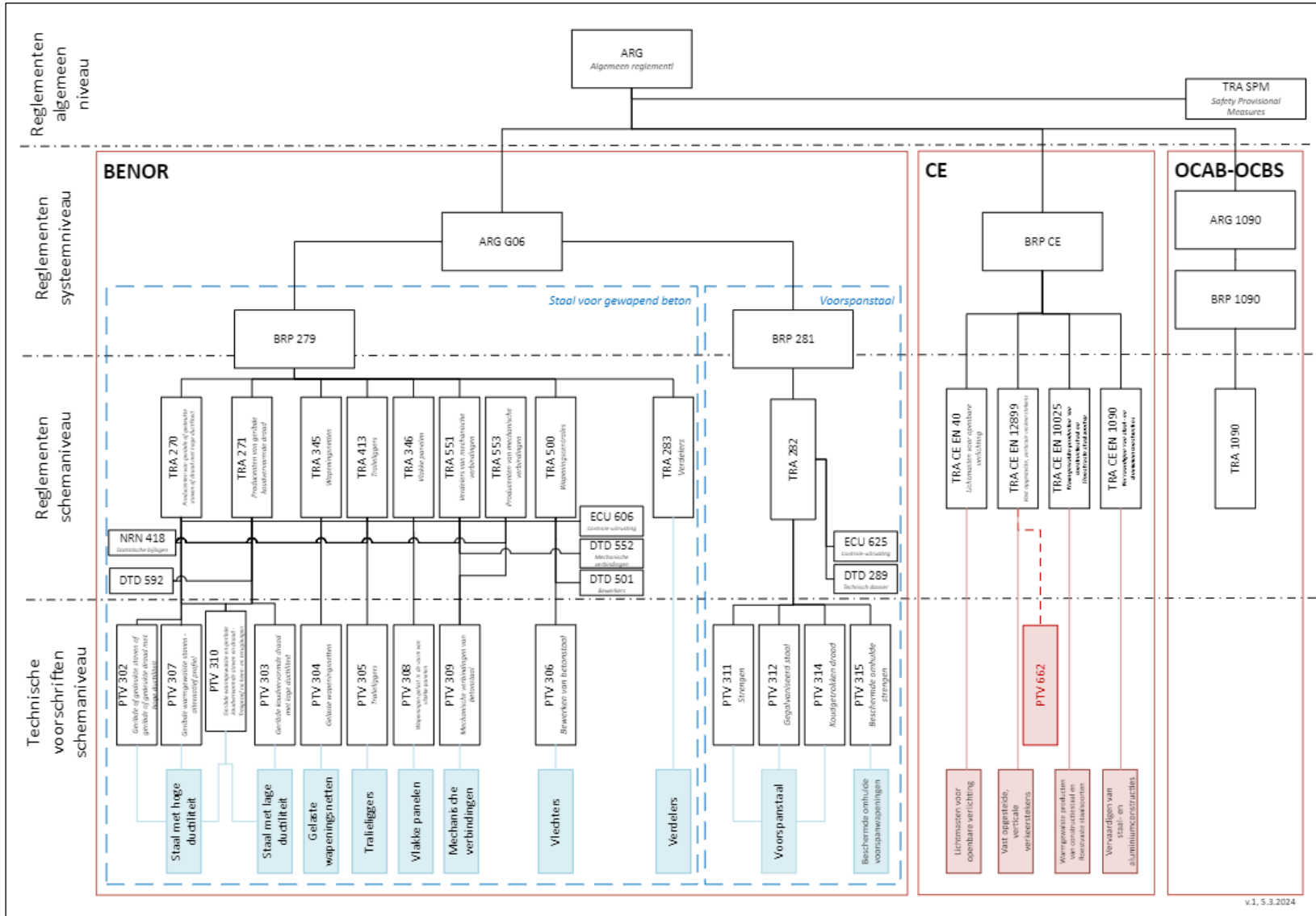

v.1, 5.3.2024

## APPENDIX B

### Management of type A and B non-conformity sheets Applicable only during periodic visits

	Responsible	Deadline (working days)	Action	NC box	Follow- up
1	OI*	During the visit or upon discovery of non-compliance	Writes an NC* report and sends it to the customer* with a response deadline If NCA If NCB	1	7 2
2	Customer	20	Submits an action plan to the OI* including an implementation deadline Refuses to sign the form, does not respond or makes comments	2	3
3	OI	10	Evaluates the proposal and sends the form and their opinion to the customer If OK If not OK or refusal to sign	3	4, 18 10
4	OI	Visit following the end of the period specified in the action plan	Verifies implementation and sends the completed form and its opinion to the customer and PROCERTUS If OK If not OK	4	5 6
5	PROCERTUS	10	Confirm the lifting of the NC to the customer with a copy to the OI	4	End**
6	OI	10	Deletes the NCB file and creates an NCA file	4	1
7	Customer	20	Submits corrective actions implemented to the OI Refuses to sign the form Proposes a deadline for corrective actions Does not follow up on the form	2	8 8 8 10
8	OI	10	Accepts or rejects corrective actions or proposed deadlines and sends the form to the customer or manufacturer and to PROCERTUS with its opinion If OK If NOK or refusal to sign If NOK and proposal for additional visit (+deadline)	3	9 10 17
9	PROCERTUS	15	Confirm the lifting of the NC to the customer with a copy to the OI	4	End**
10	PROCERTUS	5	Submits the file to AT and CC after requesting explanations from the customer, if necessary	---	11
11	AT/CC	10	Provides its opinion to PROCERTUS with a proposed decision and/or sanction	---	12
12	PROCERTUS	5	Means the decision to the user with a copy to the OI If additional visit If other sanctions	---	13 14
13	OI		Carry out the additional visit and inform the customer of the follow-up If OK If not OK	4	15 1
14	PROCERTUS	10	Informs the customer of the penalty and follows up.	4	End**
15	OI	10	Proposes to close the file at PROCERTUS	4	16
16	PROCERTUS	10	Confirm the lifting of the NC to the customer with a copy to the OI	4	End**
17	OI	Expected timeframe	Evaluate corrective actions and send the form to the customer If OK If not OK	4	9 10
18	PROCERTUS		Checks the notice and records the file for follow-up	---	4
*	IO: inspection body Client: certificate holder and/or producer AT: technical advisory group CC: certification committee NC: non-conformity sheet				
**	During the next visit, the IO shall pay particular attention to the problem that gave rise to the initial report. Any recurrence shall automatically result in the issuance of a new NCA.				